

88-

88-

vector interrupt

real time clock

88-VI

PARTS LIST

FEBRUARY, 1976

BAG 1

1	7805	101074
1	8214	101128
1	74LS75	101117
1	8T97	101040
1	7404 101022 (or)	74L04 101073
1	74L30	101082
1	74L20	101039
1	74L02	101072
1	7403	101014
2	74LS73	101119
4	74LS14	101123

BAG 2

9	1K 1/2w	101928
8	4.3K ohm 1/2w	101995

BAG 3

2	33uf 16V	100326
12	.1uf 12V	100348

BAG 4

2	Card Guides	101714
1	100 Pin Connector	101864
1	Heat Sink (large)	101870
4	6-32 x 3/8" Screw	100925
1	6-32 x 1/2" Screw	100918
1	6-32 Nut	100933
1	#6 Lock Washer	100942
3	Ferrite Bead	101876

MISC.

1	88-VI PC Board	100185
1	88-VI Manual	101526

88-
88-

vector interrupt

real time clock

CONTENTS

88-Vi theory of operation

88-RTC theory of operation

88-Vi & 88-RTC schematic diagram

88-Vi & 88-RTC assembly procedure

88-Vector Interrupt Theory of Operation

The CPU has a single interrupt input. However, once this line becomes active and an interrupt is acknowledged, the CPU can be directed to jump to any one of eight different locations in lower memory. These locations are 0, 10, 20, 30, 40, 50, 60 and 70 (octal). The Restart (RST) instruction forces the CPU to one of these eight locations. The octal code for RST is 3A7. A is a 3 bit code which represents one of the eight locations available, i. e. 307 = RST 0, 317 = RST 10, 327 = RST 20, etc.

One purpose of the Vectored Interrupt Board is to put the RST instruction on the data buss with the correct 3 bit address at the correct time. The other purpose is to allow only the highest active priority of the eight levels to interrupt the CPU. Each interruptable device interface (88-PIO, -SIO, etc.) has provisions for connecting its interrupt line to one of the eight buss lines, VI0-VI7, fed into the 88-VI. The buss lines are prioritized in the 88-VI; VI0 is highest priority and VI7 is lowest.

When an interrupt occurs that is a higher priority than any others occurring simultaneously, the 88-VI interrupts the CPU and then puts the RST instruction with the 3 bit address associated with that priority level on the data buss. When the CPU executes the RST instruction, it jumps to the address associated with that level. Suppose a CRT terminal is connected to an 88-SIOA board and the input interrupt on the board is strapped to VI4 [Note: The ENABLE INTERRUPT instruction (373) must have been executed prior to this sequence]. When a key is pressed on the CRT, it pulls VI4 low. Assuming that VI0, VI1, VI2 and VI3 are inactive, the 88-VI pulls $\overline{\text{PINT}}$ low into the buss. When the CPU acknowledges this, the 88-VI puts RST4 (347, octal) on the buss. When the CPU executes this instruction, it jumps to octal location 40. The software interrupt service routine for the CRT must be at locations 40-47. If these eight bytes of memory are not sufficient to service the device, the routine must in turn jump to another user defined section of memory.

This structure allows an interrupt routine to be interrupted by a higher level, and the higher level by an even higher level and so on up to seven deep, still insuring that each lower routine will be returned to and fully executed.

<p>NOTE: A system designed to use the 88-VI may <u>not</u> have any I/O board strapped for single level interrupt. Interrupts on I/O boards must be hardwire connected to one of the eight 88-VI interrupt levels.</p>
--

Initializing and Updating

The 88-VI (RTC) uses I/O address 254 (decimal) or 376 (octal). An output to this address causes the following to occur:

DATA BIT	FUNCTION
0 1 2	Bits 0, 1 and 2 represent the current interrupt level and prevent lower priority levels from interrupting. The software service routine sets the data bits according to its level [the routine at level 4 (or location 40 octal) outputs a 100 for bits 2, 1 and 0 respectively].
3	Data bit 3 disables the current level register (bits 0, 1 and 2 above). This bit should be output as a 0 (low) only during initialization. Normal operation defines current priority as uninterruptable by another level of the same or lesser priority, so that if data bit 3 is not set by the initialization, level 7 can not interrupt.
4	A high resets the interrupt generated by the Real Time Clock (See RTC Theory of Operation).
5	A high clears the counter network for the clock frequency of the RTC. This bit should be set high during initialization. (See RTC Theory of Operation).
6	A high enables the RTC interrupt. A low disables the RTC interrupt.
7	A high enables the 88-VI structure. A low disables the 88-VI structure.

Vector Interrupt Programming

When an interrupt occurs, the vector interrupt hardware forces the CPU to execute a RST instruction. The RST instruction saves the current program counter in the stack, then branches to the appropriate location (0, RST 0; 10, RST 1; 20, RST 2; 30, RST 3; 40, RST 4; 50, RST 5; 60, RST 6; 70, RST 7). First, the interrupt service routine saves all CPU registers on the stack, then, if required, jumps out of the RST locations to the rest of the service routine. The program for interrupt level 2 would appear as follows: (Q represents octal)

OCTAL LOCATION	INSTRUCTION
20	PUSH B
21	PUSH D
22	PUSH H
23	PUSH PSW
24	JMP LEV2

NOTE: As soon as the interrupt RST instruction is executed, interrupts are automatically disabled.

```

LEV2   LDA     CURLEV      ;GET LEVEL INTERRUPTED
        PUSH   PSW        ;SAVE OLD LEVEL ON STACK
        MVI   A,15Q       ;SET CURRENT LEVEL
        STA   CURLEV
        ORI   300Q        ;OR IN BITS REQUIRED BY VI BOARD
                                ;ORI 330Q SHOULD BE SUBSTITUTED
                                ;IF THE RTC IS HOOKED TO THIS LEVEL
        OUT   376Q
        EI
        .
        .
        .                   ;DEVICE SERVICE ROUTINE
        .                   ;GOES HERE
        .
        DI
        POP   PSW        ;POP OLD INTERRUPT LEVEL
        STA   CURLEV      ;RESTORE CURLEV
    
```

```

OFF:   ORI       3000      ;"OR" IN BITS FOR VI
BOTI:  OUT       376Q     ;TELL VI BOARD WHAT LEVELS TO ACCEPT
      POP       PSW      ;RESTORE ALL REGISTERS
      POP       H
      POP       D
      POP       B
      EI                ;ENABLE THE INTERRUPTS
      RET            ;RETURN FROM INTERRUPT

```

During this program, the following occurs: The previous interrupt level (in CURLEV) is saved on the stack. The current interrupt level is output to the VI board in order to prohibit interrupts at level 2 or levels of any lesser priority (in this case, 3, 4, 5, 6, or 7) from interrupting. The current interrupt level is saved in CURLEV. Interrupts are then re-enabled to allow execution of higher priority interrupts. At this point, the appropriate device service routine should be executed. After the service routine is completed, interrupts are disabled. The previous interrupt level, saved in CURLEV is re-stored in CURLEV and output to the VI controller. The registers are then popped off of the stack, interrupts are reenabled, and the interrupt service routine returns.

The interrupt routine is the same for all interrupt levels, except for instruction 3 (MVI). The following chart indicates the correct MVI instruction for each of the eight interrupt levels. Level 0 is the highest priority interrupt level, and level 7 is the lowest. Note also that instruction 5 requires that 330 be substituted for 300 if the RTC is hooked to this level, thereby allowing the RTC to interrupt when serviced.

Interrupt Level	RST Address	Instruction
0	0	MVI A,17Q
1	10	MVI A,16Q
2	20	MVI A,15Q
3	30	MVI A,14Q
4	40	MVI A,13Q
5	50	MVI A,12Q
6	60	MVI A,11Q
7	70	MVI A,10Q

88-Real Time Clock Theory of Operation

The 88-Real Time Clock (RTC) generates an interrupt, after a precise interval of time, which enables software to time certain routines and even to generate the correct time, day and year, upon request.

The RTC source may be selected from either a derivative of the 2 megahertz clock or the line frequency. Both the clock and line frequency offer respective advantages. The 2 megahertz clock should be used if your needs demand a fast RTC; it is selectable for time intervals down to every 100 microseconds. The line frequency (60 Hertz), on the other hand, should be used in systems that require accuracy over a long period of time. Power companies constantly adjust frequency, thus ensuring a consistent source.

The table below shows the frequency and associated time interval for both sources at each of the four selectable divide rates:

SOURCE	DIVIDE RATE	DIVIDE FREQUENCY (HZ)	TIME INTERVAL
Line Frequency (60 Hertz)	1	60	16.67 milli-seconds
	10	6	166.7 milli-seconds
	100	.6	1.67 seconds
	1000	.06	16.67 seconds
10,000 Hz (a derivative of the 2 MHz system clock)	1	10,000	100 microseconds
	10	1,000	1 millisecond
	100	100	10 milliseconds
	1000	10	100 milliseconds

NOTE: The time interval represents the frequency at which the RTC will cause an interrupt. For example, if 1000 Hz is selected, the RTC will generate an interrupt every 1000th of a second or 1000 interrupts/second.

Address 254 (decimal) is used to control the RTC (see 88-VI Theory of Operation):

Bit 4: When high, bit 4 clears the interrupt generated by the RTC. Interrupt on most I/O boards is cleared by reading or writing the data channel of the board. The RTC does not operate in this manner. The service routine that handles the RTC must output bit 4 high in addition to the three bit code which represents its RST address.

Bit 5: When high, the clock divide circuit, including the circuit that divides the 2 megahertz to 10,000 Hz, is cleared. Bit 5 should be output high during initialization and when it is necessary to start at time zero.

Bit 6: When high, bit 6 enables the RTC interrupt. When low, bit 6 disables the RTC from generating an interrupt.

Electrical Theory

I. Control Functions

An output to the 88-VI (address 376) causes the following to occur:

Address lines A1-A7 and $\overline{A0}$ are fed to gate L, thereby partially enabling P5, when the incoming address equals 376 (octal). When "OUT" instruction (323) is executed, SOUT goes high and \overline{PWR} goes low to enable P6. This signal acts as a strobe pulse to clock in data bits 0-7. The four low bits (0-3) are written into the current status register that is internal to IC "B" (8214). If bit 4 is high, the RTC interrupt flip flop, IC Fb is cleared. IC Fb should be cleared by the RTC service routine. If bit 5 is high, G6 goes low to reset clock divide circuits R, V, W, U and S. If bit 6 is high, Hb 9 goes high to enable the RTC (G9). Bit 7 high forces Ha 12 high and Ha 13 low to enable the vectored interrupt structure.

II. VI Operation

The status of the eight interrupt levels is strobed into IC "B" (8214) via the clock input, pin 6, every clock cycle. If one of the eight interrupt levels (VI0-VI7) goes low as a result of I/O activity or the RTC interrupts, IC "B" will compare this level to the current level latched into the status register. If the incoming interrupt is a higher priority than the current interrupt, IC "B" generates an interrupt (pin 5) and the three bit code that correlates to the incoming level. Pin 5 of IC "B" strobes the corresponding three bit code into latch IC "C" and clocks IC Fb in order to force IC Fb pin 8 low. Assuming that IC "D" pin 15 is low (VI is enabled), IC "D" and \overline{PINT} also go low. \overline{PINT} is the interrupt request to the CPU. If the CPU interrupt is enabled (via the EI instruction, 373) the CPU will complete execution of the current instruction, generate an interrupt acknowledge signal SINTA, then a disable signal, PINTE. PINTE disables IC "B" from accepting another interrupt until RST has been executed. At this time, the three bit code (data bits DI3, DI4 and DI5) is gated onto the buss with SINTA and PDBIN. These three data input bits are normally high. After the CPU fetches the RST instruction, the CPU pushes the program counter (PC) onto the stack and then jumps to the location in lower memory represented by the RST instruction. Note that the CPU interrupt is disabled and must be re-enabled by the service routine in order to allow interrupts of a higher priority to be accepted.

III. RTC Operation

The 2 megahertz system clock, $\overline{\text{CLOCK}}$, is divided into a 10 Khz clock by 4-bit binary counters ICs "R" and "V", and is available as jumper "CF". The unrectified positive voltage (buss line #55) is voltage divided by resistors R19 and R20 and fed to Schmitt trigger gates (IC "T"). These gates convert the incoming sin wave to a square wave. This signal or square wave is available at jumper "LF".

One of the two source frequencies is jumpered to "S", then fed to jumper "A" and the clock input of decade counter (IC "W"). The output of IC "W" is equal to the source input divided by 10, then fed to "B" and IC "U". IC "U" divides the subsequent frequency by 10 (jumper "C"), as does IC "S" (jumper "D"). Thus, the incoming frequency appears at "A", is divided by 10 at "B", is divided by 100 at "C", and is divided by 1000 at "D". One of these frequencies is jumpered to "IN" and becomes the RTC frequency input. When the RTC is enabled (see RTC Theory), the square wave at the clock input of IC Fb causes IC Fb pin 12 to go high each time the square wave goes low. IC Fb pin 12 is inverted through open-collector gate H3 and fed to jumper "RI".

When "RI" is jumpered to one of the eight interrupt levels, it generates an interrupt each time the selected time interval occurs. The RTC interrupt is then acknowledged, and the CPU jumps to the RTC service routine. The service routine must output bit 4 high to clear IC Fb (gates K10 and K4).

$\overline{\text{POC}}$ (power-on-clear) ensures that all functions on the 88-VI (RTC) are disabled when power is first applied. The ferrite beads (L1, L2 and L3) are installed to help suppress noise. Unregulated positive voltage is fed to VR1 which regulates the voltage at +5 volts.

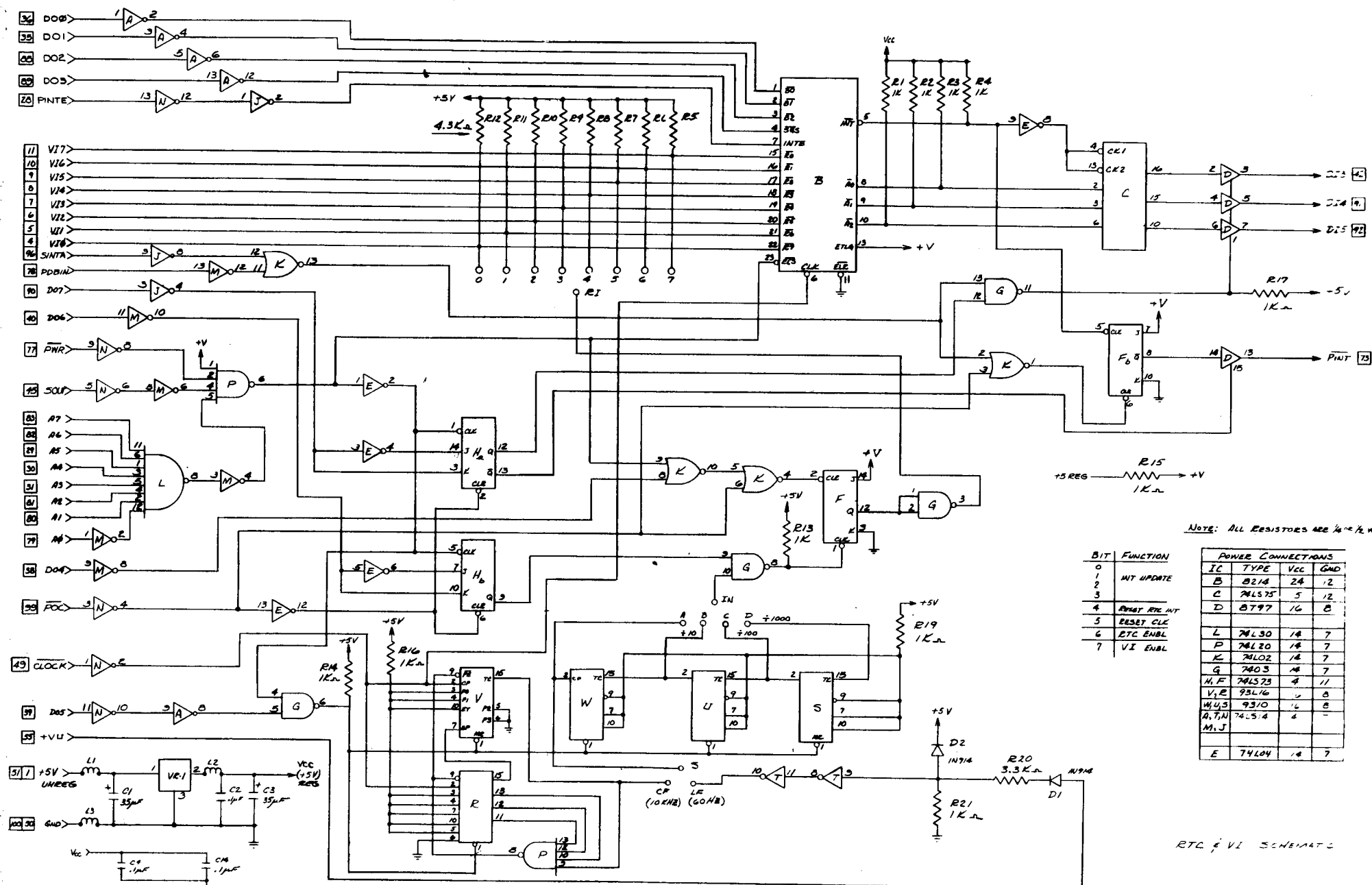

NOTE: ALL RESISTORS ARE 1/4 WATT 5%

BIT	FUNCTION
0	
1	INT UPDATE
2	
3	
4	RESET RTC INT
5	RESET CLK
6	RTC ENBL
7	VI ENBL

POWER CONNECTIONS			
IC	TYPE	VCC	GND
B	7418	24	12
C	74LS75	5	12
D	8797	16	8
L	74LS30	14	7
P	74LS20	14	7
G	7403	14	7
M,F	74LS73	4	11
V,E	9316	5	8
M,U,S	9310	16	8
A,T,N	74LS14	4	-
M,J			
E	74104	14	7

RTC & VI SCHEMATIC

1 Pmt of 487.

88 -
88 -

vector interrupt

real time clock

ASSEMBLY PROCEDURE

88-Vector Interrupt

and

88-Real Time Clock

Assembly

The 88-Vector Interrupt (88-VI) may be purchased alone OR with the 88-Real Time Clock (88-RTC). The installation instructions for both boards are included together in this manual. Each time that a component for the 88-RTC is mentioned, it will be marked by an asterisk. IGNORE THE RTC COMPONENTS IF YOU ARE CONSTRUCTING ONLY THE 88-VI.

SOCKET INSTALLATION

There is one 24-pin socket to be installed on the 88-VI board. The socket is labeled B on the component layout. Referring to the parts chart on page 4 and the component layout on page 5, use the following procedure to install each socket.

1. Be certain that the socket pins are straight. If any of the pins are bent, CAREFULLY straighten them with the tip of a small screwdriver.
2. Set the socket into place, and secure it with a piece of masking tape.
3. Turn the board over and solder each pin to the foil pattern of the back of the board. Be sure that EACH pin is soldered, and be careful not to leave any solder bridges.
4. Turn the board over again, and remove the masking tape.
5. After each socket is installed, check the corresponding socket off of the parts list on page 4.

IC INSTALLATION

There are 13 integrated circuits to be installed on the 88-VI board (A, C, D, E, F, G, H, J, K, L, M, N, P) and six integrated circuits to be installed on the 88-Real Time Clock board (R*, S*, T*, U*, V*, W*). IC B on the 88-VI board is provided with a 24-pin socket and will also be installed at this time.

To prepare ICs for installation:

Referring to the component layout on page 4, remove the IC with the correct part number from its holder. If there are any bent pins, straighten them with a needle-nose pliers. Ensure that you choose the IC with the correct part number as you install each one.

All ICs are damaged easily and should be handled carefully. Always try to hold the IC by the ends, touching the pins as little as possible.

All ICs must be oriented so that the notched end is toward the end with the arrowhead printed on the board. Pin 1 of the IC should correspond with the pad marked with the arrowhead. If the IC does not have a notch on one end, refer to the IC Orientation Chart included with your manual for the identification of Pin 1.

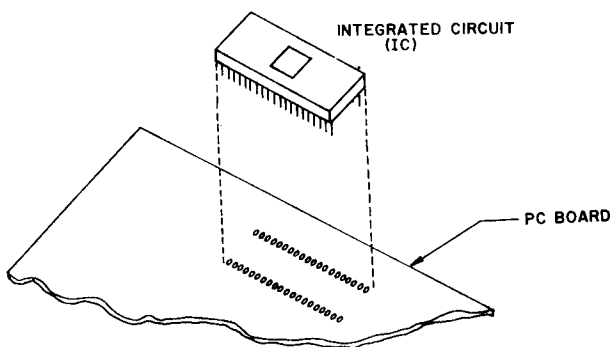

Referring to the parts chart on page 4 and the component layout on page 5, install the ICs according to the following procedure:

1. After the IC is correctly oriented, start the pins on one side of the IC into their respective holes on the silk-screened side of the board. DO NOT PUSH THE PINS IN ALL THE WAY. If you have difficulty getting the pins into the holes, use the tip of a small screwdriver to guide them.
2. Start the pins on the other side of the IC into their holes in the same manner. When all of the pins have been started, set the IC into place by gently rocking it back and forth until it rests as closely as possible to the board. After you are certain that the IC is perfectly straight and as close to the board as possible, tape it in place with a piece of masking tape.
3. Turn the board over and solder each pin to the foil pattern on the back side of the board. Be sure to solder EACH pin, and be careful not to leave any solder bridges.
4. Turn the board over again, and remove the piece of masking tape.
5. After each IC is installed, check the corresponding IC off of the parts list provided on page 4.

Referring to the parts chart on page 4 and the component layout on page 5, install IC B as follows:

1. Insert the 3214 or 8214 IC (B) into the socket on the 88-VI board. Handle the IC carefully, and use as little pressure as possible when inserting the IC.

SOCKETS AND ICS

Silk Screen Designation	Part	Number
() A	IC	74LS14
() B	IC and Socket	3214 or 8214
() C	IC	74LS75
() D	IC	8T97
() E	IC	74L04
() F	IC	74LS73
() G	IC	7403
() H	IC	74LS73
() J	IC	74LS14
() K	IC	74L02
() L	IC	74L30
() M	IC	74LS14
() N	IC	74LS14
() P	IC	74L20
() R*	IC	93L16
() S*	IC	9310
() T*	IC	74LS14
() U*	IC	9310
() V*	IC	93L16
() W*	IC	9310

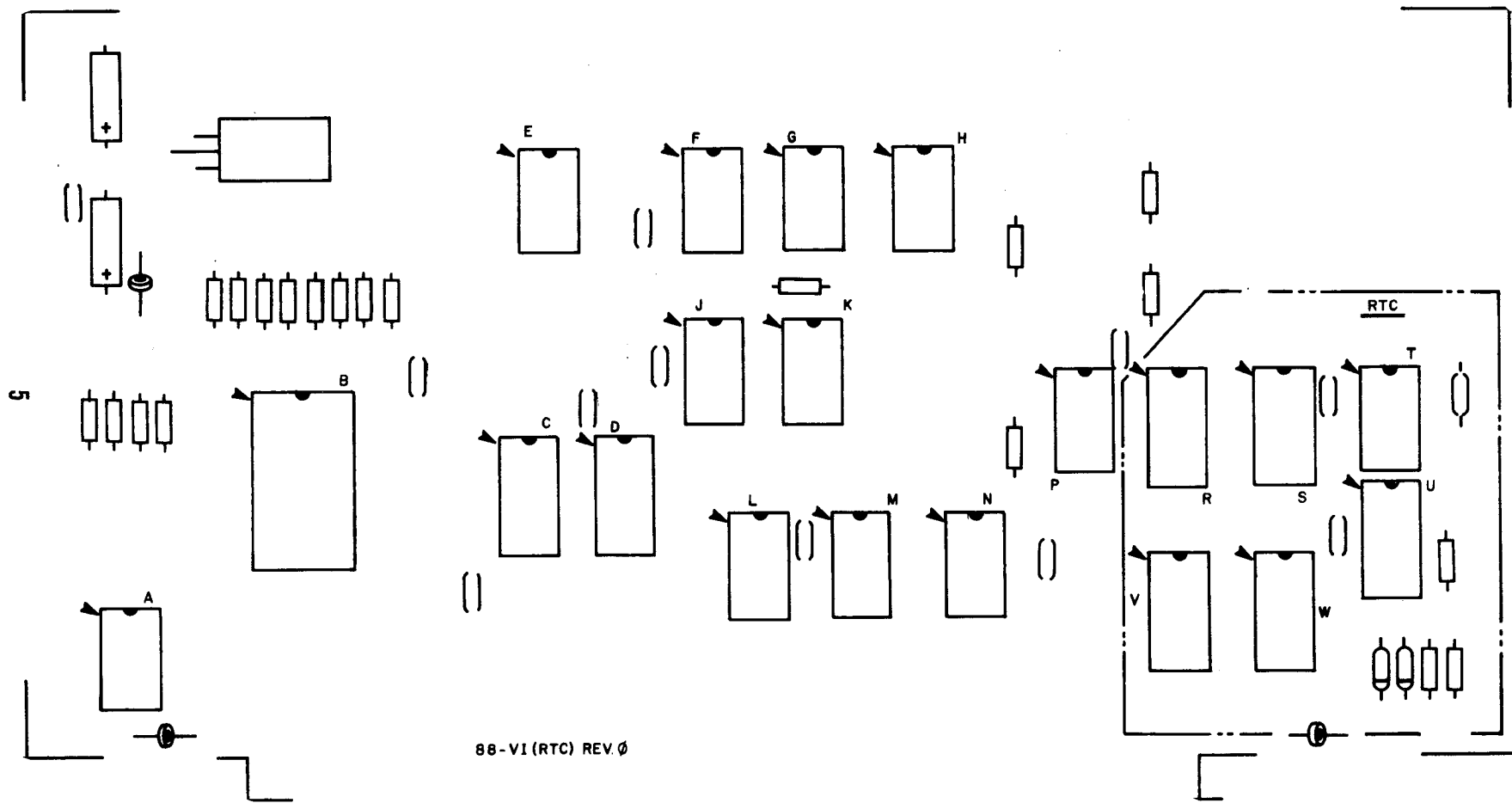

88-VI (RTC) REV. 0

RESISTOR INSTALLATION

There are 17 resistors (R1-R17) to be installed on the 88-VI board and three resistors (R19*, R20*, R21*) to be installed on the 88-RTC board.

NOTE: Resistors are color-coded according to their value. The resistors in your kit will have four bands of color. The fourth band in both cases will be gold or silver, indicating the tolerance. In the following instructions, only the three bands of color to one side of the gold or silver band are significant. Be sure to match these three bands of color with those called for in the instructions as you install each resistor.

Referring to the parts chart on page 7 and the component layout on page 8, install each resistor according to the following procedure.

1. Match the color bands designated on the parts chart with the resistor position indicated by the component layout.
2. Using needle-nose pliers, bend the leads of the resistor at right angles to match their respective holes on the board.
3. Insert the resistor into the correct holes from the silk-screened side of the board. Push the resistor down until it almost touches the foil pattern.
4. Holding the resistor in place, turn the board over and bend the leads slightly outward.
5. Solder the two leads to the foil pattern on the back side of the board. Clip off any excess lead lengths, and save them for hardware connections to be made later.
6. After making sure that there are no solder bridges, check the resistor off of the parts list.

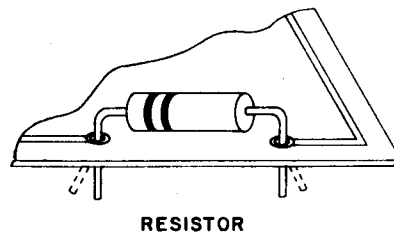

RESISTORS

- () R1, Brown-Black-Red, 1/4 or 1/2 W.
- () R2, Brown-Black-Red, 1/4 or 1/2 W.
- () R3, Brown-Black-Red, 1/4 or 1/2 W.
- () R4, Brown-Black-Red, 1/4 or 1/2 W.
- () R5, Yellow-Orange-Red, 1/4 or 1/2 W.
- () R6, Yellow-Orange-Red, 1/4 or 1/2 W.
- () R7, Yellow-Orange-Red, 1/4 or 1/2 W.
- () R8, Yellow-Orange-Red, 1/4 or 1/2 W.
- () R9, Yellow-Orange-Red, 1/4 or 1/2 W.
- () R10, Yellow-Orange-Red, 1/4 or 1/2 W.
- () R11, Yellow-Orange-Red, 1/4 or 1/2 W.
- () R12, Yellow-Orange-Red, 1/4 or 1/2 W.
- () R13, Brown-Black-Red, 1/4 or 1/2 W.
- () R14, Brown-Black-Red, 1/4 or 1/2 W.
- () R15, Brown-Black-Red, 1/4 or 1/2 W.
- () R16, Brown-Black-Red, 1/4 or 1/2 W.
- () R17, Brown-Black-Red, 1/4 or 1/2 W.
- () R19*, Brown-Black-Red, 1/4 or 1/2 W.
- () R20*, Orange-Orange-Red, 1/4 or 1/2 W.
- () R21*, Brown-Black-Red, 1/4 or 1/2 W.

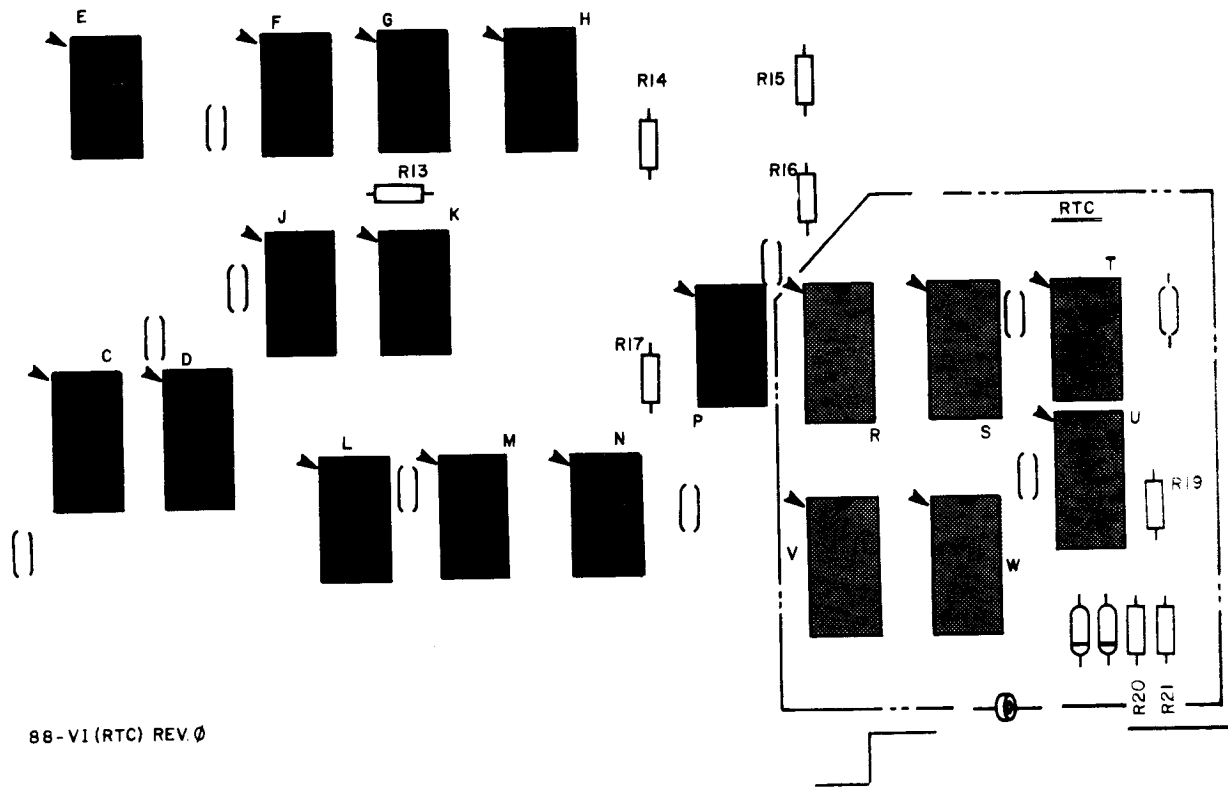
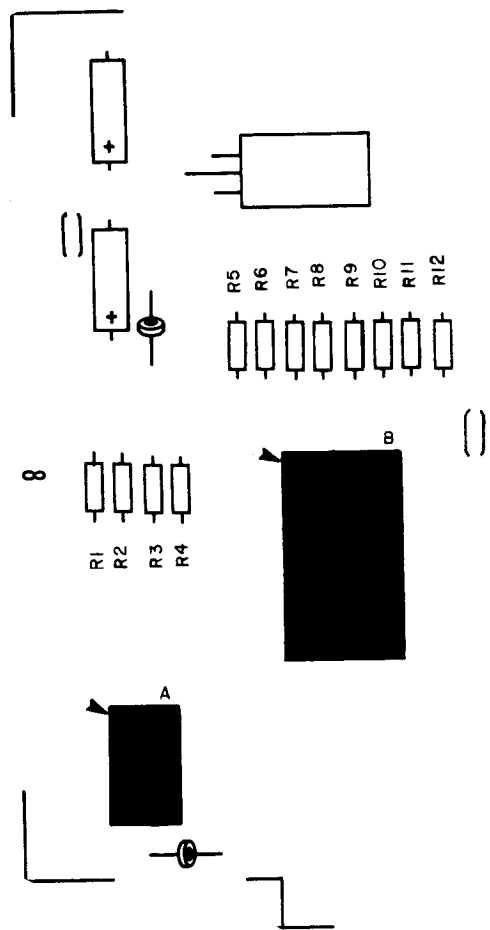

88-V1 (RTC) REV. 0

CAPACITOR INSTALLATION

The 88-VI board requires nine .1 μ f capacitors (C2, C4, C5, C6, C7, C8, C9, C10, C11) and two 33 μ f electrolytic capacitors. The 88-RTC board requires three .1 μ f capacitors (C12*, C13*, C14*).

The 33 μ f capacitors are designated electrolytic because their polarity requirements must be noted before installation.

The polarity markings of each of the two electrolytic capacitors for the 88-VI board will appear as one of the following types:

ELECTROLYTIC
CAPACITOR

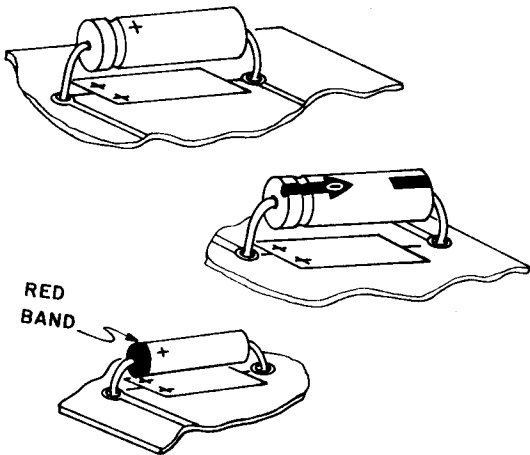

If the marking is the arrow type, a negative sign will appear in the tip of the arrow. Orient the capacitor so that the arrow points to the negative polarity side. If the marking is one of the other two types, orient the capacitor so that the positive signs match the positive polarity side. Polarity is designated on the silk-screened side of the board.

Referring to the component layout on page 10 and the parts chart on page 11, install each electrolytic capacitor (C1, C3) as follows:

1. Referring to the parts chart, choose an electrolytic capacitor with the value that matches the part number.
2. Bend the two leads of the capacitor at right angles to match their respective holes on the board. Insert the capacitor into the holes on the silk-screened side of the board. Be sure to orient the capacitor correctly.
3. Holding the capacitor in place, turn the board over and bend the two leads slightly outward. Solder the two leads to the foil pattern, and clip off any excess lead lengths.
4. After making sure that there are no solder bridges, check each electrolytic capacitor off of the parts list as you install it.

Referring to the parts chart on this page and the component layout on page 11, use the following procedure to install each of the .1 μ f capacitors on the 88-VI board (C2, C4, C5, C6, C7, C8, C9, C10, C11) and on the 88-RTC board (C12*, C13*, C14*).

1. Using needle-nose pliers, straighten the two leads as necessary to fit their respective holes on the board.
2. Insert the capacitor into the correct holes from the silk-screened side of the board. Push the capacitor down until the ceramic insulation almost touches the foil pattern.
3. Holding the capacitor in place, turn the board over and bend the two leads slightly outward. Solder the leads to the foil pattern and clip off any excess lead lengths.
4. Be sure that there are no solder bridges, and check each capacitor off of the parts list on this page after it is installed.

CAPACITORS
() C1, electrolytic, 33 μ f.
() C2, .1 μ f.
() C3, electrolytic, 33 μ f.
() C4, .1 μ f.
() C5, .1 μ f.
() C6, .1 μ f.
() C7, .1 μ f.
() C8, .1 μ f.
() C9, .1 μ f.
() C10, .1 μ f.
() C11, .1 μ f.
() C12, .1 μ f.
() C13, .1 μ f.
() C14, .1 μ f.

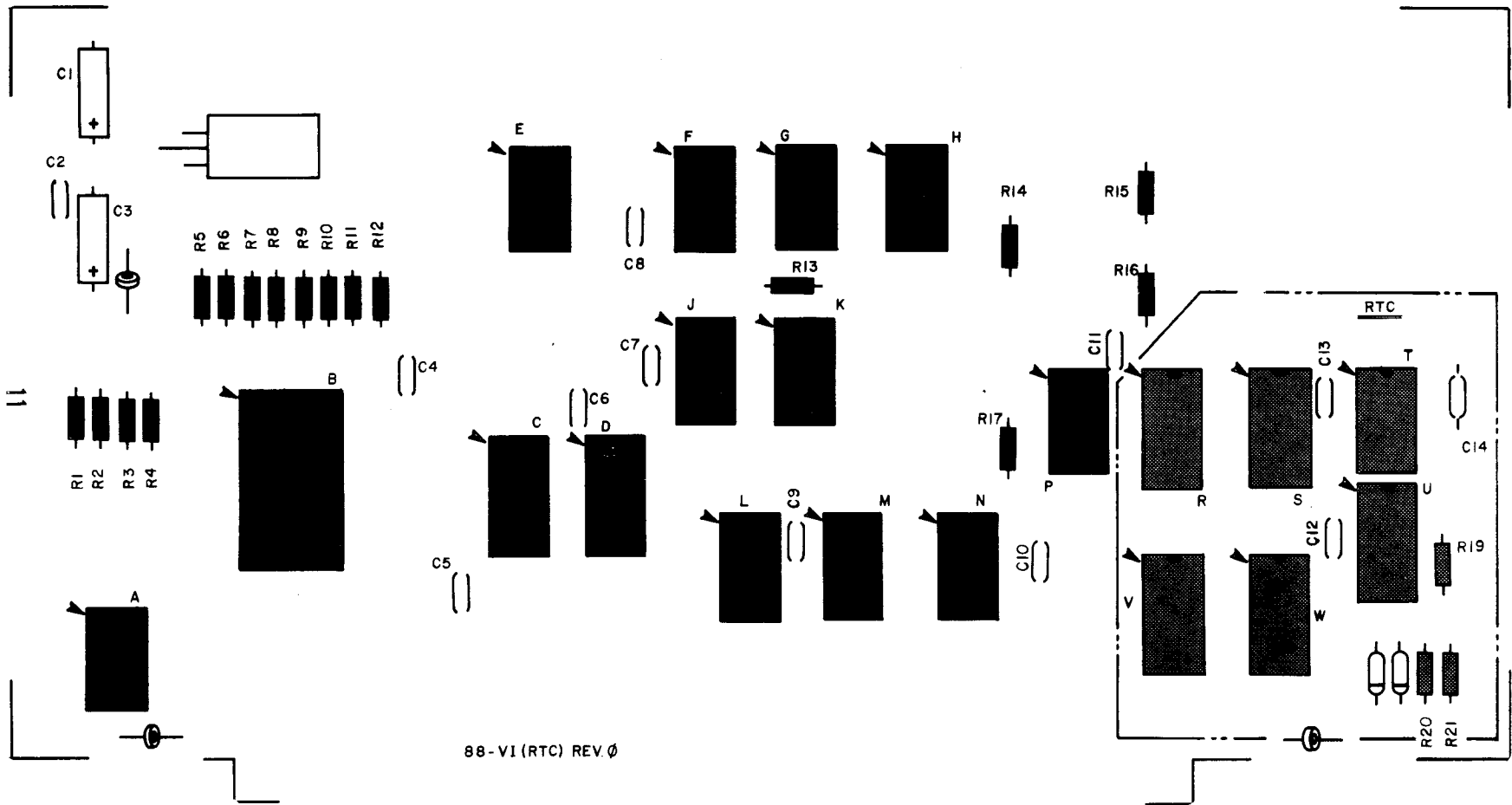

DIODE INSTALLATION*

There are two 1N914 diodes to be installed on the 88-RTC board (D1*, D2*).

NOTE: Diodes are marked with a band to indicate the cathode end. The diode must be oriented so that the banded end corresponds with the band printed on the 88-RTC board. Failure to orient diodes correctly may result in permanent damage to your unit.

Referring to the parts chart and the component layout on this page, install each diode according to the following instructions.

1. Bend the leads of the diode at right angles to match the correct holes on the board.
2. Be certain that the banded end of the diode matches the band on the silk-screened side of the board.

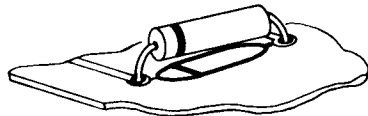

DIODE

Insert the diode into the correct holes from the silk-screened side of the board. Turn the board over, and bend the leads slightly outward.

3. Solder the two leads to the foil pattern on the back side of the board. Clip off any excess lead lengths. Check each diode off of the parts list as it is installed.

DIODES
() D1*, 1N914
() D2*, 1N914

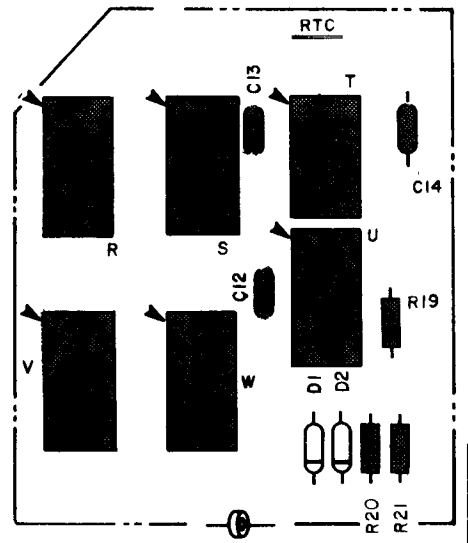

INDUCTANCE COIL INSTALLATION

There are two inductance coils to be installed on the 88-VI board (L1, L2) and one inductance coil to be installed on the 88-RTC (L3*).

Referring to the parts chart on this page and the component layout on page 14, install the inductance coils according to the following instructions.

1. Using wires saved from earlier in the assembly procedure, insert a wire through the bead or cylindrical-shaped inductance coil.
2. Using needle-nose pliers, bend the leads of the inductance coil at right angles to match their respective holes on the board.
3. Insert the inductance coil into the correct holes from the silk-screened side of the board. Push the bead part of the coil down until it almost touches the foil pattern.
4. Holding the coil in place, turn the board over and bend the leads slightly outward.
5. Solder the two leads to the foil pattern on the back side of the board; then clip off any excess lead lengths.
6. After making sure that there are no solder bridges, check the coil off of the parts list.

INDUCTANCE COILS
() L1
() L2
() L3*

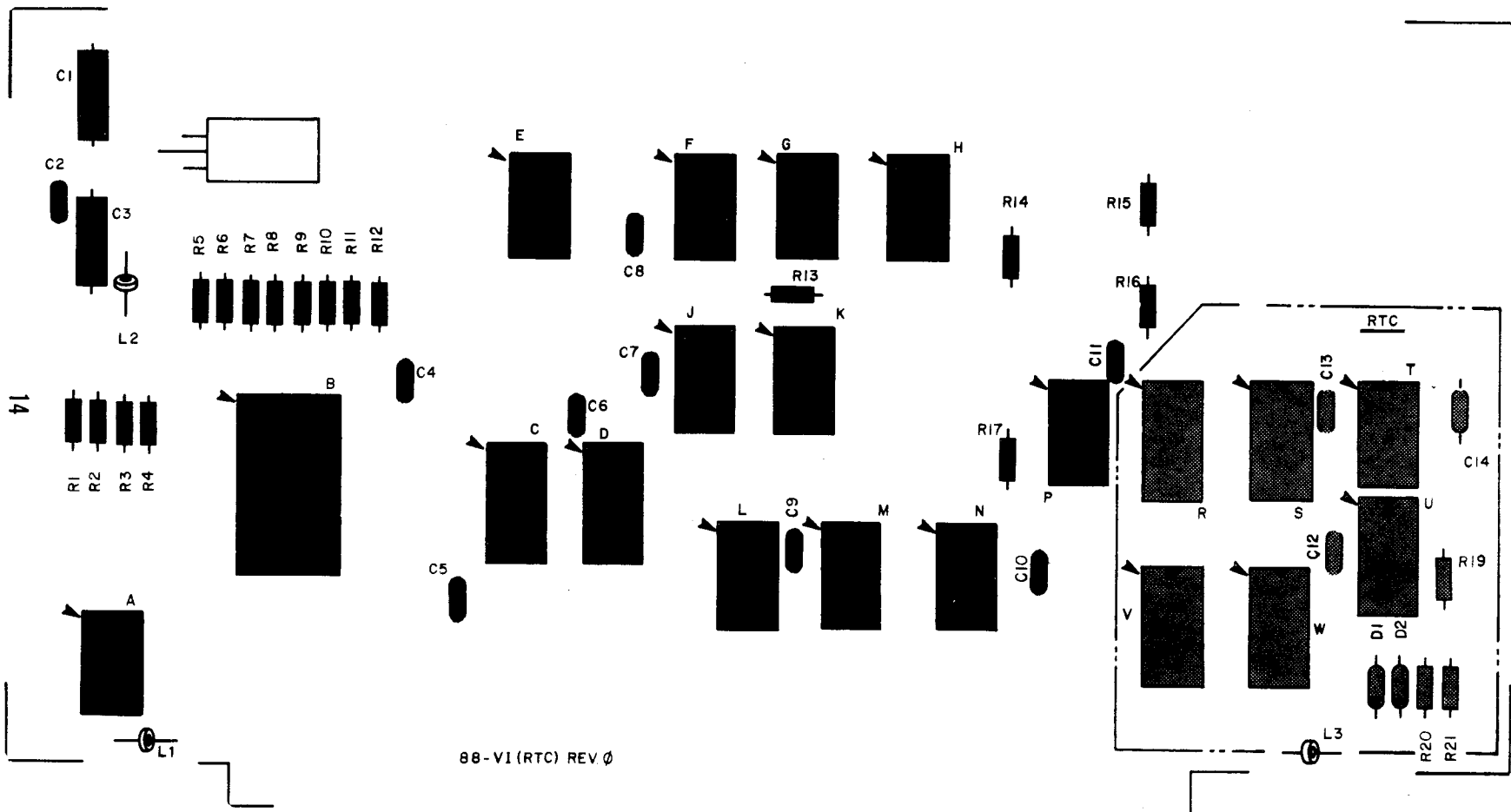

VOLTAGE REGULATOR INSTALLATION

There is one 5-volt or 7805 voltage to be installed on the 38-VI board.

Referring to the component layout and the illustration below, install the voltage regulator as follows:

1. Set the voltage regulator in place on the board and align the mounting holes. (See drawing below.)

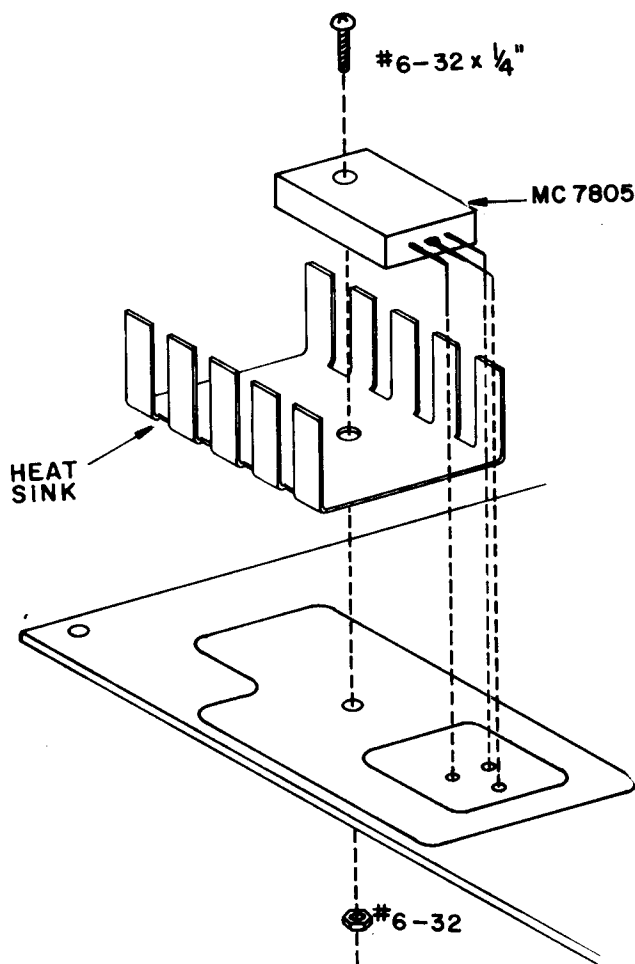

2. Use a pencil to mark the point on each of the three leads where they line up with their respective holes on the board.

3. Using needle-nose pliers, bend each of the three leads at a right angle on the points where you made the pencil marks.

NOTE: Use heat-sink grease when installing this component. Apply the grease to all surfaces which come in contact with each other.

4. Referring to the preceding drawing, set the regulator and heat sink in place on the silk-screened side of the board. Secure the regulator and heat sink as shown by the drawing, holding the regulator in place as you tighten the nut.
5. Turn the board over and solder the three leads to the foil pattern on the back side of the board. Be sure not to leave any solder bridges.
6. Clip off any excess lead lengths, and place a checkmark in the blank provided below.

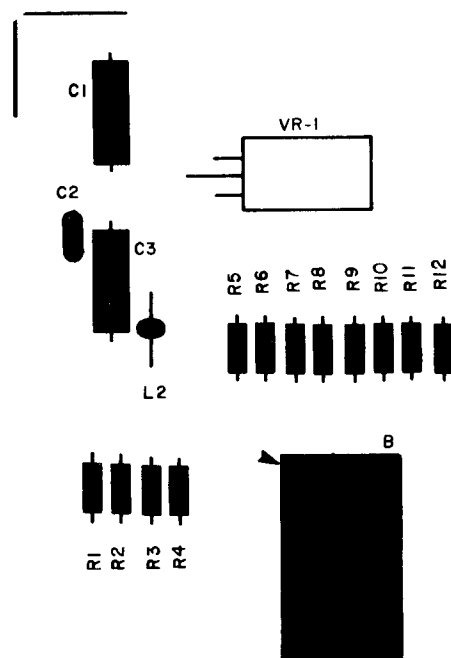

HARDWIRE CONNECTIONS*

The 88-RTC board must be hardwire connected for interrupt level. Hardwire connections for the 88-RTC also include one of two source input options and an optional frequency divide. All hardwire connections must be made with wires saved earlier in the assembly procedure.

All of the following instructions apply ONLY if you are constructing the 88-RTC as well as the 88-VI.

To hardwire the 88-RTC board for interrupt level, refer to the component layout on page 17 and make the following connections.

1. Choose which interrupt line you wish to implement, 0, 1, 2, 3, 4, 5, 6, or 7. The highest priority level is 0 and the lowest is 7.
2. Connect RI (located to the left of IC "C") to level 0, 1, 2, 3, 4, 5, 6, or 7.
3. Bend the leads of the wire to fit the corresponding holes. Insert the leads into the correct holes from the silk-screened side of the board.
4. Turn the board over and solder the leads to the foil pattern on the back side of the board. Clip off any excess lengths.

The 88-RTC board offers two source input options. The board may be hardwired for line frequency (60 cycles/second) or a derivative of the system clock (10,000 cycles/second).

Referring to the component layout on page 17, connect the source input as follows:

1. Choose which option you wish to implement, 60 cps or 10,000 cps.

2. If you wish to implement the 60 cps source input, connect S (located below ICs "V" and "W") to LF. If you wish to implement the 10,000 cps source input, connect S to CF.
3. Bend the leads of the wire to fit the corresponding holes. Insert the leads into the correct holes from the silk-screened side of the board.
4. Turn the board over and solder the leads to the foil pattern on the back side of the board. Clip off any excess lengths.

The 88-RTC source input may or may not be further divided. If you wish to implement frequency divide, refer to the component layout on page 17, and make the following connections.

1. Choose which frequency divide you wish to implement, A, B, C, or D. A represents $\div 1$, B represents $\div 10$, C represents $\div 100$, and D represents $\div 1,000$. Refer to the Theory of Operations for a complete explanation of the resultant frequencies and time intervals for each frequency divide operation.
2. Connect pad IN (located above ICs "R" and "S") to pad A, B, C, or D.
3. Bend the leads of the wires to fit the corresponding holes. Insert the leads into the correct holes from the silk-screened side of the board.
4. Turn the board over and solder the leads to the foil pattern on the back side of the board. Clip off any excess lengths.

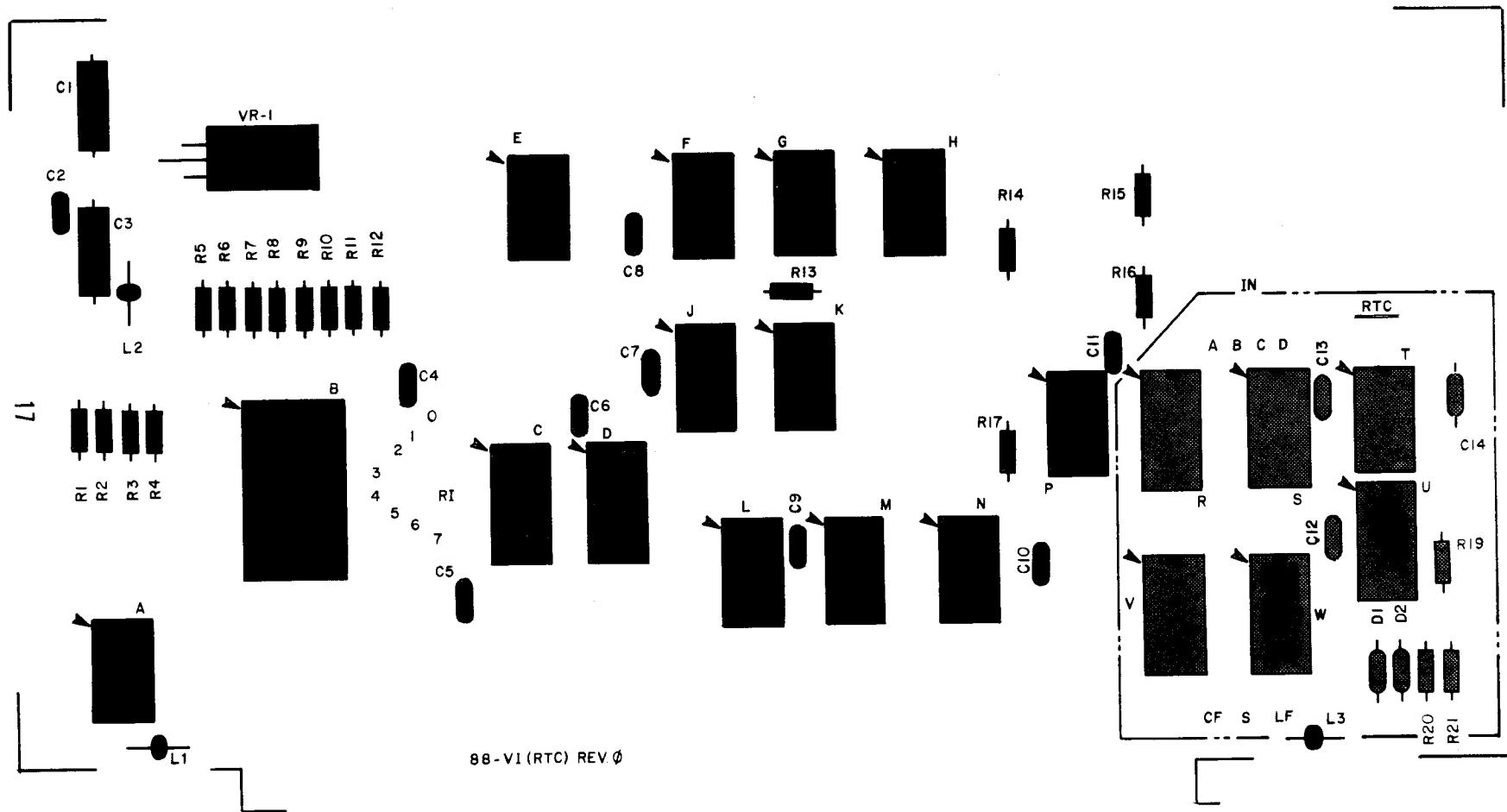

BOARD INSTALLATION

Install the edge connector provided with the board according to the procedure described on page 64 in the assembly manual. "EXPANDER BOARD 8800 M/BD ASSEMBLY".

Press the 88-VI board into the edge connector. The board should be oriented so that the silk-screened side faces the right side of the unit when viewed from the front panel.

If you are constructing the 88-RTC, a hardwire connection must be made between the Mother board and the power supply board. This connection brings the unrectified +16 volts to buss #55 for use as the line frequency input for the 88-RTC. Make this connection according to the following procedure.

1. If the computer is assembled in its case, remove the chassis by unscrewing the four screws located on either side of the case.
2. Use insulated wire and connect Diode 5 (D5) on the power supply board from the anode side (side that faces the front panel) to pin 55 of the Mother board. The insulated wire should lay in a position so that it extends from D5, between the mounted boards and the transformer, to pin 55 of the Mother board.
3. Bend one lead of the insulated wire side of D5. Solder the wire.
4. Bend the other lead of the insulated wire to fit into pin 55 of the Mother board. Insert the leads into the correct hole.
5. Tip the chassis and solder the lead to the foil pattern on the bottom side of the Expander board. Clip off any excess lead lengths.

A machine language program for the 88-RTC has been developed which keeps track of hours, minutes, seconds and 60ths of seconds in four consecutive memory locations. This program uses 8K BASIC, a USR assembly language subroutine, and an interrupt response subroutine. To execute the program, strap the RTC for line frequency in ± 1 , and load the following program using Package I (assembler, editor, monitor). Note that Q represents octal.

```

START:   ORG      17673Q      ;PROGRAM STARTS AT THIS MEMORY LOCATION
        PUSH    PSW          ;STACK ALL REGISTERS TO BE USED
        PUSH    B
        PUSH    H
        LDA     CURLEV       ;PICK UP OLD LEVEL NUMBER
        PUSH    PSW          ;SAVE IT ON THE STACK
        MVI    A,10Q        ;NEW LEVEL IS 10Q
        STA     CURLEV       ;STORE THIS AS THE NEW CURRENT LEVEL
        ORI    330Q         ;OR IN BITS NEEDED TO RESET RTC AND VI BOARD
        OUT    254          ;OUTPUT LEVEL INFO TO VI BOARD
        EI
        MVI    B,3
        LXI    H,NMB        ;GET ADDRESS OF 60TH'S OF SECONDS COUNTER
LOOP:    MOV    A,M          ;PICK UP COUNTER
        INR    M            ;INCREMENT COUNTER
        SBI    59           ;CHECK IF COUNTER IS NOW = TO 60
        JNZ    OUTLP        ;IF < 60 WE ARE DONE
        MOV    M,A          ;IF = 60 ZERO OUT COUNTER
        INX    H            ;POINT AT NEXT COUNTER
        DCR    B            ;DECREMENT NUMBERS OF COUNTERS LEFT TO CHECK
        JNZ    LOOP         ;LOOP TILL 60TH'S, SECONDS, AND MINUTES ARE DONE
        MOV    A,M          ;NOW CHECK HOURS COUNTER
        INR    M
        SBI    23           ;MAKE SURE NOT MORE THAN 24 HOURS
        JNZ    OUTLP
OUTLP:   MOV    M,A
        DI
        POP    PSW          ;POP OLD INTERRUPT LEVEL OFF STACK
        STA     CURLEV       ;STORE AGAIN AS CURRENT LEVEL
        ORI    300Q         ;OR IN CONTROL BITS FOR VI
        OUT    254          ;OUTPUT CURRENT LEVEL TO VI BOARD
        POP    H            ;RESTORE ALL REGISTERS USED
        POP    B
        POP    PSW
        EI
        RET                ;RETURN TO INTERRUPTED PROGRAM
NMB:    DS      5
CURLEV: DB      0
INIT:   MVI    A,360Q       ;INITIALIZE THE VI BOARD
        OUT    254
        EI
LAST:   RET
        END      TIM

```

UNDEFINED SYMBOLS

SYMBOL TABLE

```
$0200000  
START 017673  
CURLEV 017771  
NMB 017764  
LOOP 017721  
OUTLP 017746  
INIT 017746  
INIT 017772  
LAST 017777
```

After the program is loaded, BASIC must be loaded into the CPU. The "memory size" question in BASIC's initialization's dialog should be answered with 8122. All other initialization questions in BASIC should be answered as usual.

After initialization, certain modifications to BASIC must be made.

1. A JMP instruction must be put at location 70, so that the interrupt will cause a JMP to the machine language interrupt response routine. Correct branching is implemented by the following three BASIC commands:

```
POKE 56,195 70, 303  
POKE 57,187 71, 273  
POKE 58,31 72, 037
```

2. The following commands allow the USR function to turn on the clock and to enable interrupts. This changes the JMP FCERR in location 72 to a JMP INIT (see symbol table).

```
POKE 73,250 111, 372  
POKE 74,31 112, 037
```

3. In order to set the time, make these commands. (Note: Set the time a few minutes ahead to allow for the time necessary to type the commands):

```
POKE 8180, TIM (60ths of a second) 037, 364  
POKE 8181, TIM (seconds) 037, 365  
POKE 8182, TIM (minutes) 037, 366  
POKE 8183, TIM (hours) 037, 367
```

The above commands could also be part of a BASIC program which asked for the initial tie as HHMMSSJJ (hours, minutes, seconds and jiffies -- 1 jiffy = 1/60 second).

EXAMPLE: If the RTC were to be set for 9:30 a.m., the commands would appear as follows:

```
POKE 8180,0
POKE 8181,0
POKE 8182,30
POKE 8183,9
```

4. In order to start the clock, type:

```
A =USR (1)
```

A printout of the correct time will be received when the following BASIC program is typed in.

```
10 DIM Z(3)
20 FOR X=1 TO 3
30 Z(X)=PEEK(8180+X)
40 NEXT X
50 PRINTZ(3);":";Z(2);":";Z(1)
RUN
Δ9Δ:Δ30Δ:Δ0
```